

The DC92P type of contactors has been designed for direct current loads, particularly motors as used on electric vehicles such as industrial trucks. The DC92P is a monoblock construction, resulting in a neat compact design which is compatible with modern electronic control systems. Developed for both interrupted and uninterrupted loads, the DC92P is suitable for switching Resistive, Capacitive and Inductive loads. The DC92P is sealed to IP66 thus offering greater protection against adverse environments such as water or dust.

- **Interrupted** current - opening and closing on load with frequent switching (results in increased contact resistance).
- **Uninterrupted** current - no or infrequent load switching requirements (maintains a lower contact resistance).

The DC92P has double breaking main contacts with silver alloy contact tips, which are weld resistant, hard wearing and have excellent conductivity. The DC92P M8 main stud terminals can be configured in a variety of ways in order to suit the application. Coil connections are by means of 6.3mm spades and mounting is via the supplied moulded bracket. Mounting can be horizontal or vertical, when vertical the contact studs should point upwards. If the requirement is for downwards orientation we can adjust the contactor to compensate for this.



DC92P

| Application   | Interrupted                  | Uninterrupted |
|---|------------------------------|---------------|
| Thermal Current Rating (I <sub>th</sub> )   | 100A                         | 125A          |
| Intermittent Current Rating:  |                              |               |
| 30% Duty  | 185A                         | 230A          |
| 40% Duty  | 160A                         | 200A          |
| 50% Duty  | 140A                         | 175A          |
| 60% Duty  | 130A                         | 160A          |
| 70% Duty  | 120A                         | 150A          |
| Rated Fault Current Breaking Capacity (I <sub>cn</sub> ) 5ms Time Constant: (in accordance with UL583*) | 800A at 48V D.C.             |               |
| Maximum Recommended Contact Voltages (U <sub>c</sub> ):   | 48V D.C.                     |               |
| Typical Voltage Drop per pole across New Contacts at 100A:  |                              |               |
| Normally Open   | 40mV                         |               |
| Mechanical Durability   | > 5 x 10 <sup>6</sup> Cycles |               |
| Coil Voltage Available (U <sub>s</sub> )  | From 6 to 240V D.C.          |               |
| Coil Power Dissipation:   |                              |               |
| Highly Intermittent Rated Types   | 20 - 30 Watts                |               |
| Intermittently Rated types  | 15 - 20 Watts                |               |
| Prolonged Rated Types   | 13 - 15 Watts                |               |
| Continuously Rated Types  | 7 - 13 Watts                 |               |
| Maximum Pull-In Voltage (Coil at 20° C) Guideline:  |                              |               |
| Highly Intermittent Rated types (Max 25% Duty Cycle)  | 60% U <sub>s</sub>           |               |
| Intermittently Rated types (Max 70% Duty Cycle)   | 60% U <sub>s</sub>           |               |
| Prolonged Operation (Max 90% Duty Cycle)  | 60% U <sub>s</sub>           |               |
| Continuously Rated Types (100% Duty Cycle)  | 66% U <sub>s</sub>           |               |
| Drop-Out Voltage Range  | 10 - 25% U <sub>s</sub>      |               |
| Typical Pull-In Time (N/O Contacts to Close)  | 20ms                         |               |
| Typical Drop-Out Time (N/O Contacts to Open):   |                              |               |
| Without Suppression   | 5ms                          |               |
| With Diode Suppression  | 50ms                         |               |
| With Diode and Resistor (Subject to resistance value)   | 8 - 20ms                     |               |
| Typical Contact Bounce Period   | 3ms                          |               |
| Operating Ambient Temperature   | - 40°C to + 60°C             |               |
| Guideline Contactor Weight  | 810 gms                      |               |

Connection Conductor Sizes for Maximum Continuous Current Should be Rated Suitable for Application

**Key:** ▾ = Interrupted ▾ = Uninterrupted

**Note:** Where applicable values shown are at 20° C

\* Please check our web site for product UL status

- Performance data provided should be used as a guide only. Some de-rating or variation from figures may be necessary according to application.
- Thermal current ratings stated are dependant upon the size of conductor being used
- For further technical advice email: [technical@albrightinternational.com](mailto:technical@albrightinternational.com)
- Albright reserve the right to change data without prior notice

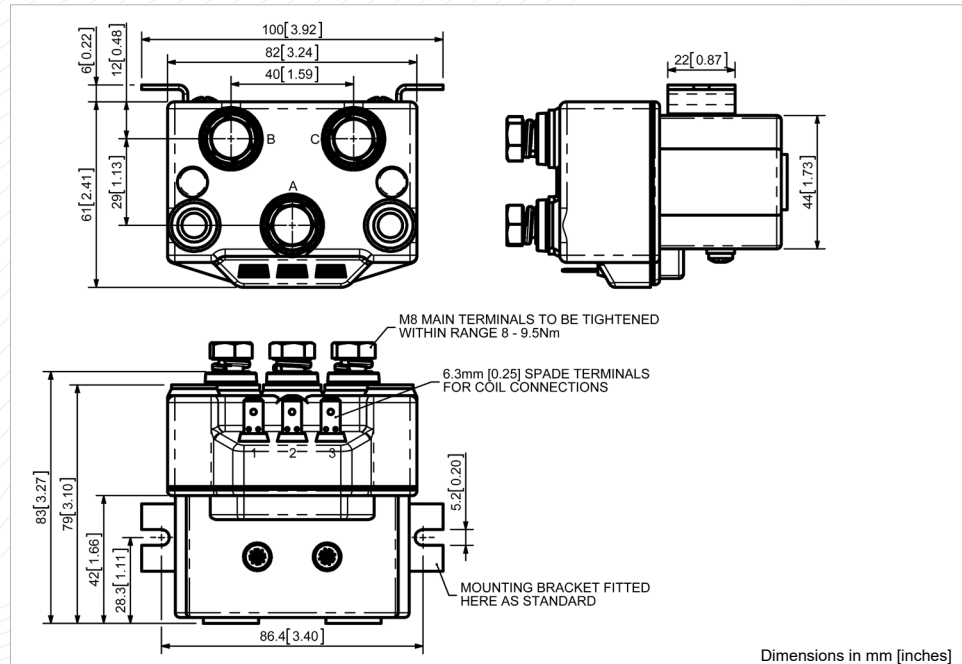

DC92P Contactor Performance

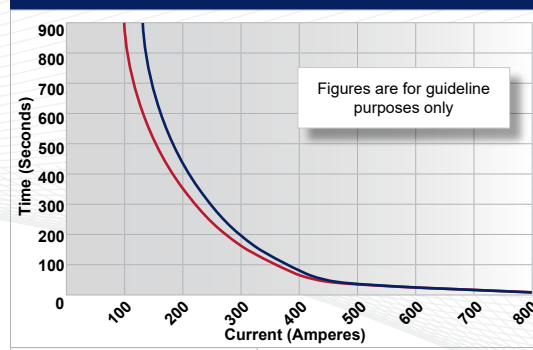

**Contact Performance Key:**

- Interrupted Current
- Uninterrupted Current

Connection Diagram

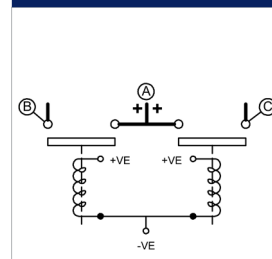

DC92P Available Options

| General   |   | Suffix |
|---|---|--------|
| Auxiliary Contacts                                | X |        |
| Auxiliary Contacts - V3                           | X |        |
| Magnetic Blowouts†                                | X |        |
| Magnetic Blowouts - High Powered†                 | X |        |
| Armature Cap                                      | X |        |
| Mounting Brackets                                 | ● |        |
| Magnetic Latching† (Not fail safe)                | ○ | M      |
| Closed Contact Housing                            | ● |        |
| Environmentally Protected IP66                    | ● | P      |
| EE Type (Steel Shroud)                            | X |        |
| Contacts  |   |        |
| Large Tips  | ○ | L      |
| Textured Tips                                     | ○ | T      |
| Silver Plating                                    | X |        |
| Coil  |   |        |
| AC Rectifier Board (Fitted)                       | X |        |
| Coil Suppression†                                 | ○ |        |
| Flying Leads                                      | X |        |
| Manual Override Operation                         | X |        |
| M4 Stud Terminals                                 | ○ |        |
| M5 Terminal Board                                 | X |        |
| Vacuum Impregnation                               | ○ |        |
| <b>Key:</b> Optional ○ Standard ● Not Available X |   |        |
| † Connections become polarity sensitive           |   |        |