

Application	Interrupted	Uninterrupted
Thermal Current Rating (¹ th)	✓	100A
Intermittent Current Rating:		
30% Duty	✓	185A
40% Duty	✓	160A
50% Duty	✓	140A
60% Duty	✓	130A
70% Duty	✓	120A
Rated Fault Current Breaking Capacity (¹ cn) 5ms Time Constant: (in accordance with UL583*)	✓	800A at 80V
Maximum Recommended Contact Voltages (U _c):		
SW822P	✓	96V D.C.
Typical Voltage Drop per pole across New Contacts at 100A	✓	50mV
Mechanical Durability	✓	>5 x 10 ⁶ Cycles
Coil Voltage Available (U _s) (Rectifier board required for A.C.)	✓	From 6 to 240V D.C.
Coil Power Dissipation:		
Highly Intermittent Rated Types	✓	20 - 30 Watts
Intermittently Rated types	✓	15 - 20 Watts
Prolonged Rated Types	✓	13 - 15 Watts
Continuously Rated Types	✓	7 - 13 Watts
Maximum Pull-In Voltage (Coil at 20° C) Guideline:		
Highly Intermittent Rated types (Max 25% Duty Cycle)	✓	60% U _s
Intermittently Rated types (Max 70% Duty Cycle)	✓	60% U _s
Prolonged Operation (Max 90% Duty Cycle)	✓	60% U _s
Continuously Rated Types (100% Duty Cycle)	✓	66% U _s
Drop-Out Voltage Range	✓	10 - 25% U _s
Typical Pull-In Time (N/O contacts to close)	✓	20ms
Typical Drop-Out Time (N/O Contacts to Open) [§] :		
Without Suppression	✓	5ms
With Diode Suppression	✓	50ms
With Diode and Resistor (Subject to resistance value)	✓	8 - 20ms
Typical Contact Bounce Period	✓	3ms
Operating Ambient Temperature	✓	- 40°C to + 60°C
Guideline Contactor Weight:		
SW822P	✓	960 gms

Advised Connection Sizes for Maximum Continuous Current		
Copper busbar	✓	80mm ² [0.124inch ²]
Cable	✓	Rated suitable for Application

Key: ✓ = Interrupted ▲ = Uninterrupted

Note: Where applicable values shown are at 20° C

* Please check our web site for product UL status

[§] The SW822 has fast drop out times and relatively slow pull-in times. Motor direction changes can be undertaken without risk of all contacts being closed at the same time. Note, some coil suppression such as diodes substantially increase drop out times and care must be taken to ensure suitable suppression is used (e.g. diode and resistor in series).

- Performance data provided should be used as a guide only. Some de-rating or variation from figures may be necessary according to application.
- Thermal current ratings stated are dependant upon the size of conductor being used
- For further technical advice email: technical@albrightinternational.com
- Albright reserve the right to change data without prior notice

The SW822P has been designed for Motor Reversing applications with direct current loads, particularly motors as used on electric vehicles such as industrial trucks. Developed for both interrupted and uninterrupted loads, the SW822P is suitable for switching Resistive, Capacitive and Inductive loads.

- **Interrupted** current - opening and closing on load with frequent switching (results in increased contact resistance).
- **Uninterrupted** current - no or infrequent load switching requirements (maintains a lower contact resistance).

The SW822P features double breaking main contacts with silver alloy tips, which are weld resistant, hard wearing and have excellent conductivity. The SW822P features an enclosed top cover and offers environmental protection to IP66. The SW822P has M8 stud main terminals and 6.3mm spade coil connections. Mounted using supplied brackets, mounting can be horizontal or vertical, when vertical the M8 contact studs should point upwards. If the requirement is for downwards orientation we can adjust the contactor to compensate for this.



SW822P

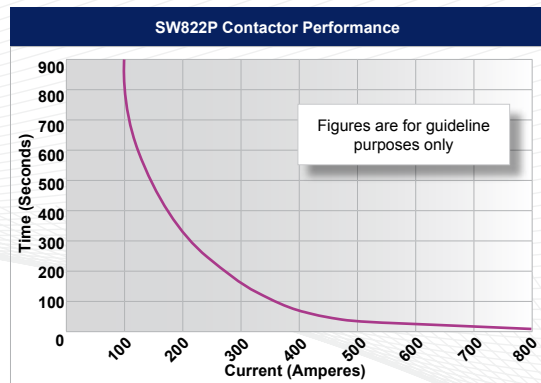
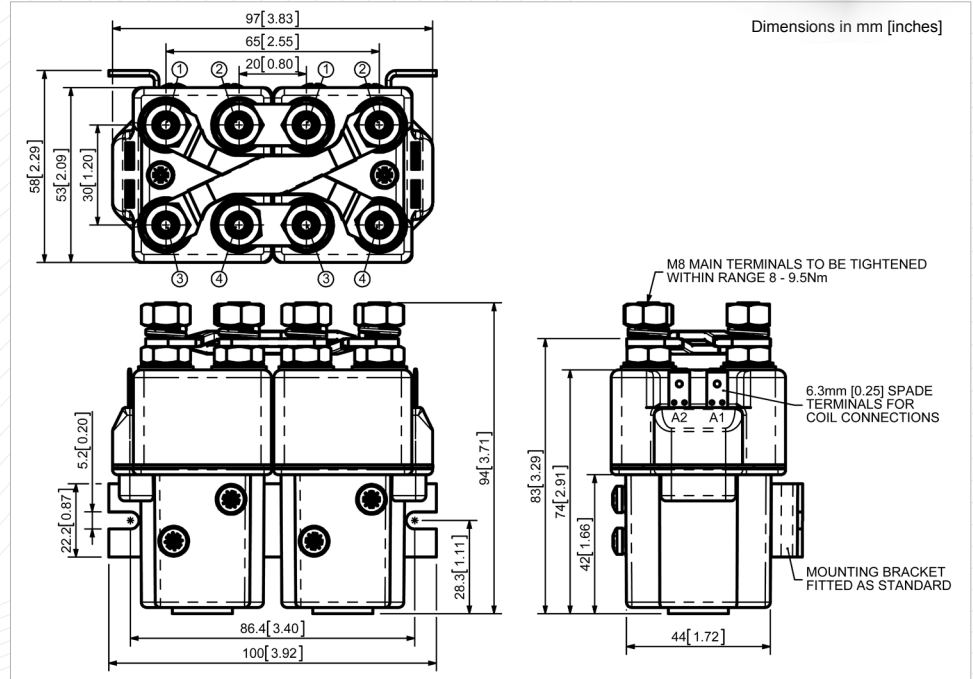

Contact Performance Key:

— Interrupted and Uninterrupted Current

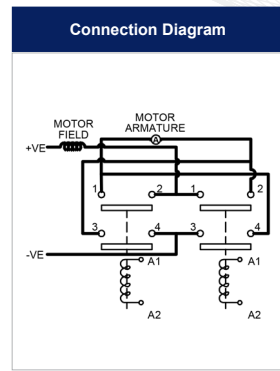

SW822P Available Options		
General		Suffix
Auxiliary Contacts	X	
Auxiliary Contacts - V3	X	
Magnetic Blowouts [†]	X	
Magnetic Blowouts - High Powered [†]	X	
Armature Cap	X	
Mounting Brackets	●	
Magnetic Latching [†] (Not fail safe)	○	M
Closed Contact Housing	●	
Environmentally Protected IP66	●	P
EE Type (Steel Shroud)	X	
Contacts		
Large Tips	○	L
Textured Tips	○	T
Silver Plating	X	
Coil		
AC Rectifier Board (Fitted)	X	
Coil Suppression [†]	○	
Flying Leads	X	
Manual Override Operation	X	
M4 Stud Terminals	○	
M5 Terminal Board	X	
Vacuum Impregnation	○	

Key: Optional ○ Standard ● Not Available X

[†] Connections become polarity sensitive