

The SW600 is designed for use in telecommunication and power distribution applications where an uninterrupted load is switched. These contactors are primarily for use with Direct Current loads but can also be used with Alternating Currents.

- Uninterrupted current - no or infrequent load switching requirements (maintains lower contact resistance).

Application	Uninterrupted
Thermal Current Rating ( $I_{th}$ )	600A
Intermittent Current Rating:	
30% Duty	1095A
40% Duty	950A
50% Duty	850A
60% Duty	775A
70% Duty	715A
Rated Fault Current Breaking Capacity ( $I_{cn}$ ) Resistive Load: (in accordance with UL508*)	
SW600	900A at 60V D.C.
Maximum Recommended Contact Voltages ( $U_e$ ):	
SW600	60V D.C.
Typical Voltage Drop per pole across New Contacts at 100A	<50mV
Mechanical Durability	>1 x 10 <sup>6</sup> Cycles
Coil Voltage Available ( $U_s$ ) (Rectifier board required for A.C.)	From 6 to 240V A.C./D.C.
Coil Power Dissipation:	
Highly Intermittent Rated Types	60 - 80 Watts
Intermittently Rated Types	30 - 60 Watts
Prolonged Rated Types	21 - 30 Watts
Continuously Rated Types	13 - 21 Watts
Maximum Pull-In Voltage (Coil at 20° C) Guideline:	
Highly Intermittent Rated types (Max 25% Duty Cycle)	60% $U_s$
Intermittently Rated types (Max 70% Duty Cycle)	60% $U_s$
Prolonged Operation (Max 90% Duty Cycle)	60% $U_s$
Continuously Rated Types (100% Duty Cycle)	66% $U_s$
Drop-Out Voltage Range	10 - 30% $U_s$
Typical Pull-In Time	40ms
Typical Drop-Out Time (N/O Contacts to Open):	
Without Suppression	10ms
With Diode Suppression	100ms
With Diode and Resistor (Subject to resistance value)	30ms
Typical Contact Bounce Period	< 5ms
Operating Ambient Temperature	-40°C to +60°C
Guideline Contactor Weight:	
SW600	1450 gms
With Auxiliary	+ 20 gms
Auxiliary Details	
Auxiliary Thermal Current Rating	5A
Auxiliary Contact Switching Capabilities (Resistive Load):	
SW600A	SW600C
	5A at 24V D.C.
	2A at 48V D.C.
	0.5A at 240V D.C.
Advised Connection Sizes for Maximum Continuous Current	
Copper busbar	387mm <sup>2</sup> [0.6inch <sup>2</sup> ]
Cable	Rated suitable for Application

**Key:** ▲ = Uninterrupted  
**Note:** Where applicable values shown are at 20° C

\* Please check our web site for product UL status

- Performance data provided should be used as a guide only. Some de-rating or variation from figures may be necessary according to application.
- Thermal current ratings stated are dependant upon the size of conductor being used
- For further technical advice email: [technical@albrightinternational.com](mailto:technical@albrightinternational.com)
- Albright reserve the right to change data without prior notice

The SW600 features double breaking main contacts with silver alloy tips which are weld resistant, hard wearing and have excellent conductivity. Silver plating on the main contacts is standard for the SW600, however, optionally it can be excluded from the specification. This compact contactor can be busbar mounted vertically or horizontally, but if mounted vertically, the coil should be at the bottom. If the coil is required at the top, we can adjust the contactor to compensate for this. Optional extras include auxiliary switches, brackets, coil finishes and magnetic latching which allows the contactor to remain closed while consuming no coil power. *Please note, although still available the SW600 has been superseded by the SW560.*

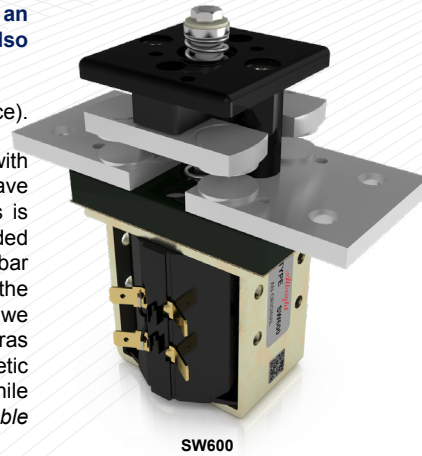

SW600

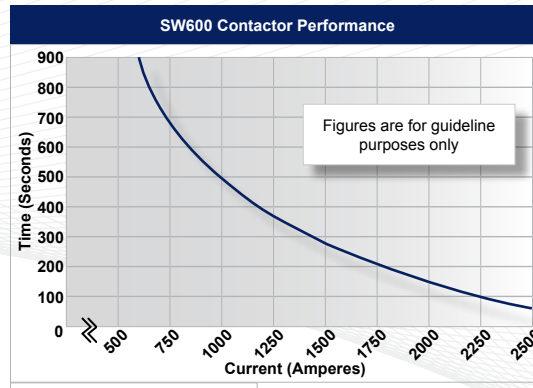
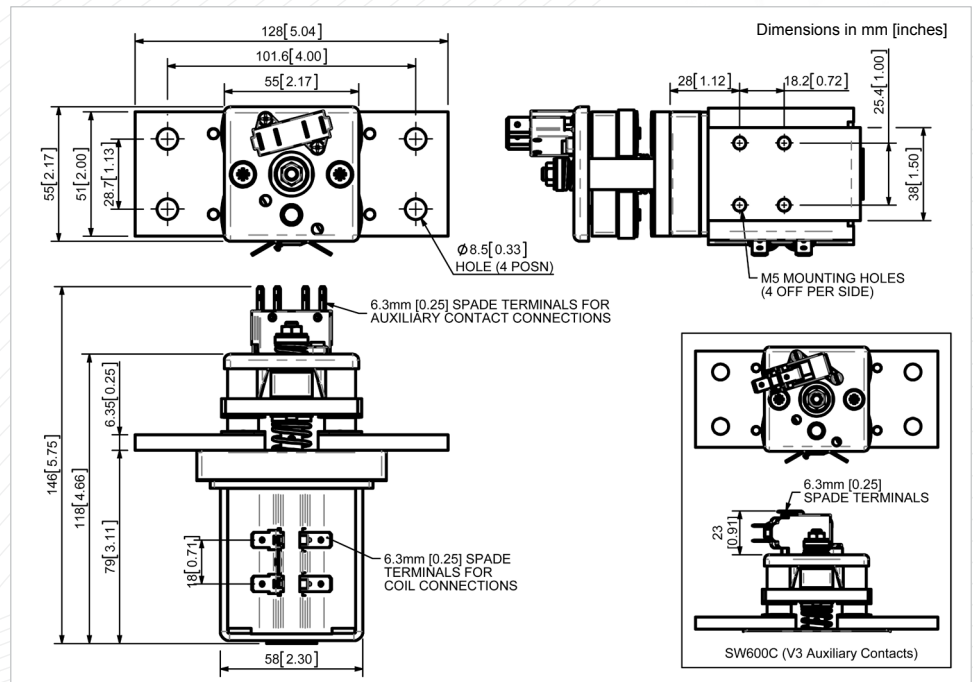

**Contact Performance Key:**

— Uninterrupted Current

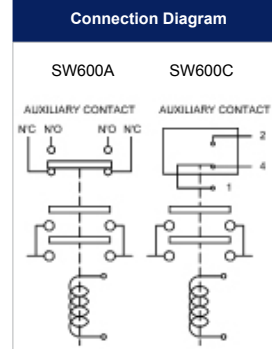

SW600 Available Options		
General		Suffix
Auxiliary Contacts	○	A
Auxiliary Contacts - V3	○	C
Magnetic Blowouts†	X	
Magnetic Blowouts - High Powered†	X	
Armature Cap	X	
Mounting Brackets (see Busbar Series Catalogue)	○	
Magnetic Latching† (Not fail safe)	○	M
Closed Contact Housing	X	
Environmentally Protected IP66	X	
EE Type (Steel Shroud)	X	
Contacts		
Large Tips	X	
Textured Tips	X	
Silver Plating	○	
Coil		
AC Rectifier Board (Fitted)	○	
Coil Suppression†	○	
Flying Leads	○	F
Manual Override Operation	○	
M4 Stud Terminals	X	
M5 Terminal Board	X	
Vacuum Impregnation	○	

**Key:** Optional ○ Standard ● Not Available X  
 † Connections become polarity sensitive