

The DC88P series of contactors has been designed for direct current loads, particularly motors as used on electric vehicles such as industrial trucks. The DC88P is a monoblock construction, resulting in a neat compact design which is compatible with modern electronic control systems. Developed for both interrupted and uninterrupted loads, the DC88P is suitable for switching Resistive, Capacitive and Inductive loads. The DC88P is sealed to IP66 thus offering greater protection against adverse environments such as water or dust.

- **Interrupted** current - opening and closing on load with frequent switching (results in increased contact resistance).
- **Uninterrupted** current - no or infrequent load switching requirements (maintains a lower contact resistance).

The main contact circuit, designed for motor reversing, has a built in failsafe, so that if both coils are energised simultaneously the contact arrangement is open circuit. The DC88P has double breaking main contacts with silver alloy contact tips, which are weld resistant, hard wearing and have excellent conductivity. The DC88P M8 main stud terminals can be configured in a variety of ways in order to suit the application. Coil connections are by means of 6.3mm spades and mounting is via the supplied bracket and can be horizontal or vertical, when vertical the M8 contact studs should point upwards. If the requirement is for downwards orientation we can adjust the contactor to compensate for this.



DC88P

Application	Interrupted	Uninterrupted
Thermal Current Rating (I _{th})		100A
Intermittent Current Rating:		
30% Duty		185A
40% Duty		160A
50% Duty		140A
60% Duty		130A
70% Duty		120A
Rated Fault Current Breaking Capacity (I _{cn}) 5ms Time Constant: (in accordance with UL583*)		800A at 48V D.C.
Maximum Recommended Contact Voltages (U _e):		48V D.C.
Typical Voltage Drop per pole across New Contacts at 100A:		
Normally Open	< 40mV	
Normally Closed	< 50mV	
Mechanical Durability	> 5 x 10 ⁶ Cycles	
Coil Voltage Available (Us)		From 6 to 240V D.C.
Coil Power Dissipation:		
Highly Intermittent Rated Types	20 - 30 Watts	
Intermittently Rated types	15 - 20 Watts	
Prolonged Rated Types	13 - 15 Watts	
Continuously Rated Types	7 - 13 Watts	
Maximum Pull-In Voltage (Coil at 20° C) Guideline:		
Highly Intermittent Rated types (Max 25% Duty Cycle)	60%U _s	
Intermittently Rated types (Max 70% Duty Cycle)	60%U _s	
Prolonged Operation (Max 90% Duty Cycle)	60%U _s	
Continuously Rated Types (100% Duty Cycle)	66%U _s	
Drop-Out Voltage Range	10 - 25%	
Typical Pull-In Time	20ms	
Typical Drop-Out Time (N/O Contacts to Open):		
Without Suppression	5ms	
With Diode Suppression	50ms	
With Diode and Resistor (Subject to resistance value)	8 - 20ms	
Typical Main Contact Changeover Time (milliseconds):		
Normally Closed to Normally Open	7ms	
Normally Open to Normally Closed	4ms	
Typical Contact Bounce Period	3ms	
Operating Ambient Temperature	- 40°C to + 60°C	
Guideline Contactor Weight	990 gms	
Connection Conductor Sizes for Maximum Continuous Current Should be Rated Suitable for Application		

Key: ▾ = Interrupted ▾ = Uninterrupted

Note: Where applicable values shown are at 20°C

* Please check our web site for product UL status

- Performance data provided should be used as a guide only. Some de-rating or variation from figures may be necessary according to application.
- Thermal current ratings stated are dependant upon the size of conductor being used
- For further technical advice email: technical@albrightinternational.com
- Albright reserve the right to change data without prior notice

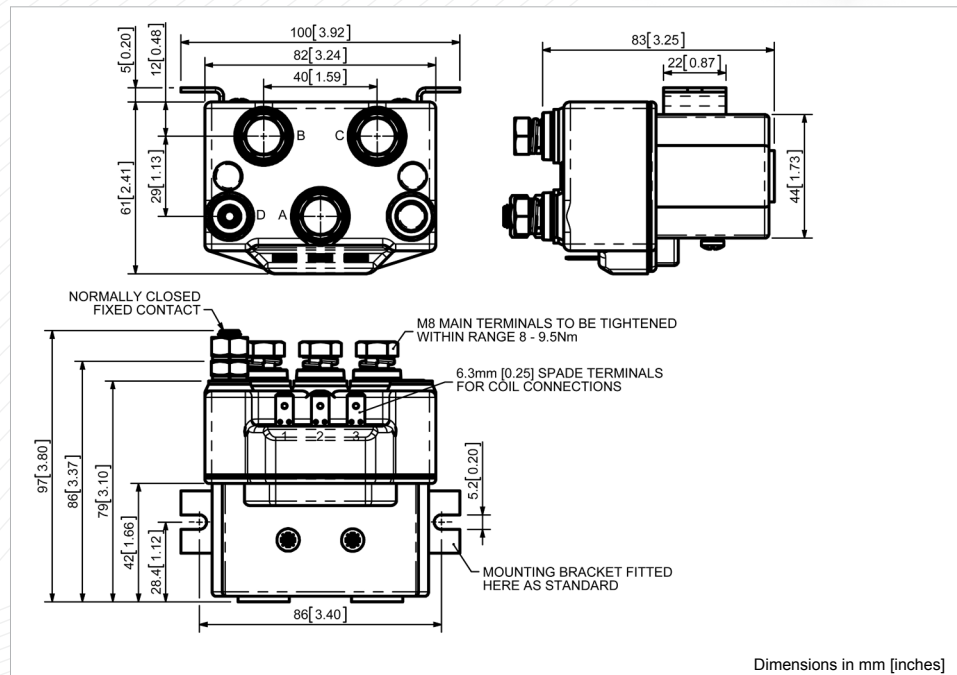

DC88P Contactor Performance

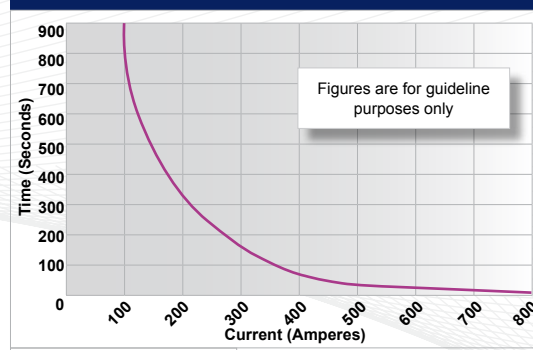

Contact Performance Key:

— Interrupted and Uninterrupted Current

Connection Diagram

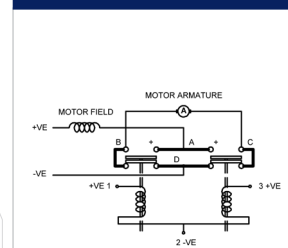

DC88P Available Options

General		Suffix
Auxiliary Contacts	X	
Auxiliary Contacts - V3	X	
Magnetic Blowouts [†]	X	
Magnetic Blowouts - High Powered [†]	X	
Armature Cap	X	
Mounting Brackets	●	
Magnetic Latching [†] (Not fail safe)	○	M
Closed Contact Housing	●	
Environmentally Protected IP66	●	P
EE Type (Steel Shroud)	X	
Contacts		
Large Tips	○	L
Textured Tips	○	T
Silver Plating	X	
Coil		
AC Rectifier Board (Fitted)	X	
Coil Suppression [†]	○	
Flying Leads	X	
Manual Override Operation	X	
M4 Stud Terminals	○	
M5 Terminal Board	X	
Vacuum Impregnation	○	

Key: Optional ○ Standard ● Not Available X
[†] Connections become polarity sensitive